

# What Happened to Zelda After She Swallowed Two Nickels, Three Dimes, and a Quarter?

Give the SURFACE AREA of each prism. Find your answer in the answer columns and notice the two letters next to it. Write these letters in the spaces over the exercise number at the bottom of the page.

①

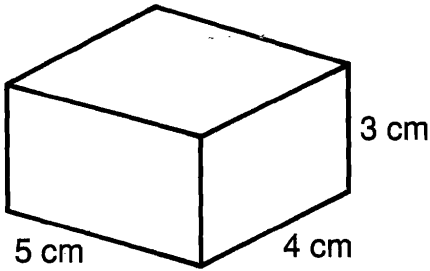

②

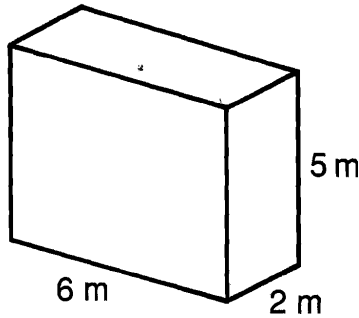

③

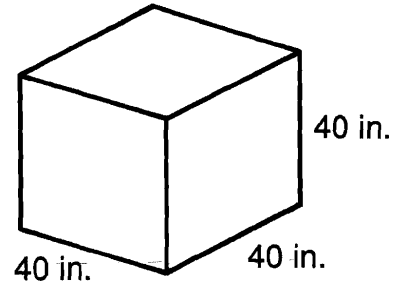

④

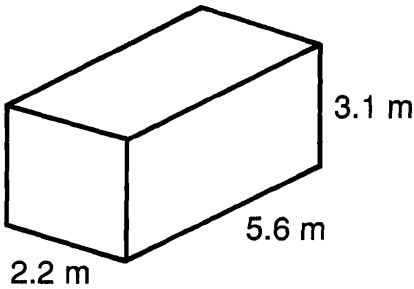

⑤

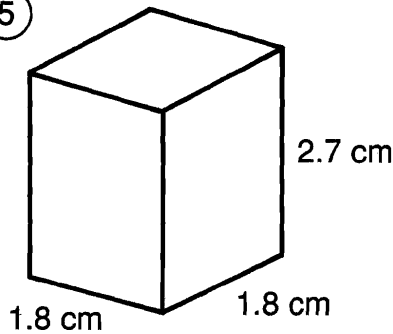

⑥

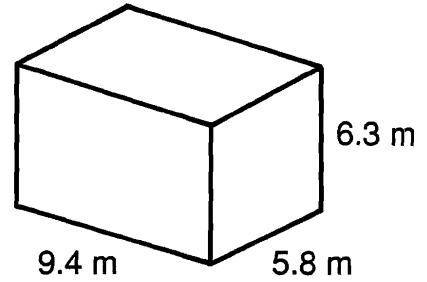

⑦

A rectangular storage box is 12 in. wide, 15 in. long, and 9 in. high. How many square inches of colored paper are needed to cover the surface of the box?

⑧

A teacher made a pair of foam dice to use in math games. Each cube measured 10 in. on a side. How many square inches of fabric were needed to cover the two cubes?

Ⓧ 73 m<sup>2</sup>

## Answers

Ⓧ 8,560 in.<sup>2</sup>

Ⓧ 23.12 cm<sup>2</sup>

Ⓧ 94 cm<sup>2</sup>

Ⓧ 318.26 m<sup>2</sup>

Ⓧ 25.92 cm<sup>2</sup>

Ⓧ 846 in.<sup>2</sup>

Ⓧ 86 m<sup>2</sup>

Ⓧ 9,600 in.<sup>2</sup>

Ⓧ 1,050 in.<sup>2</sup>

Ⓧ 104 m<sup>2</sup>

Ⓧ 1,200 in.<sup>2</sup>

Ⓧ 300.56 m<sup>2</sup>

Ⓧ 85 cm<sup>2</sup>

4	2	7	1	5	8	3	6												

# What Is Cold And Comes In Cans?

Find the surface area of each figure. Cross out the box containing each correct answer. When you finish, write the letters from the remaining boxes in the spaces at the bottom of the page.

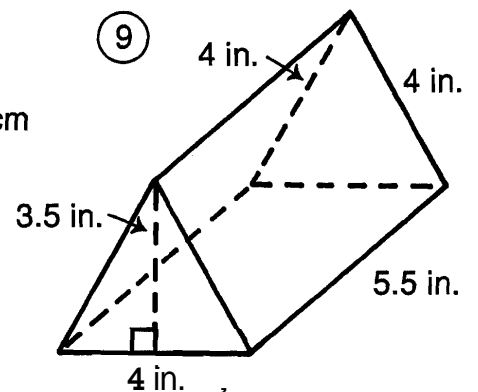
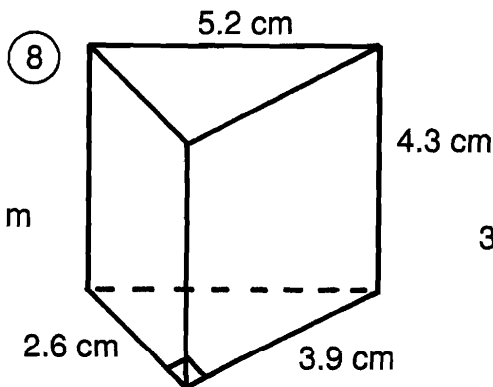
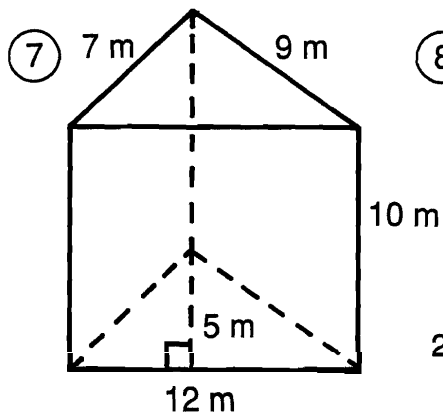
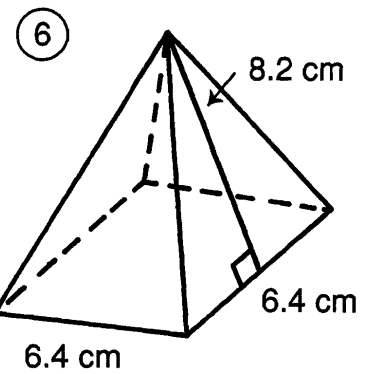
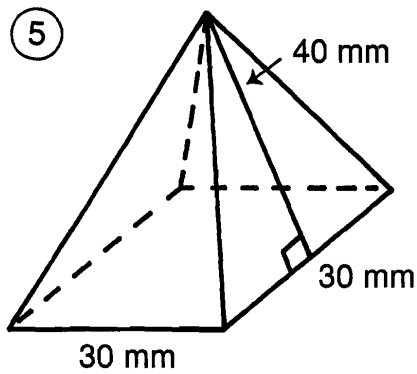
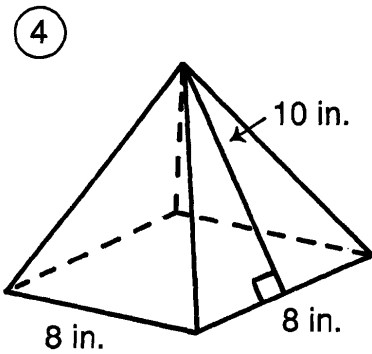
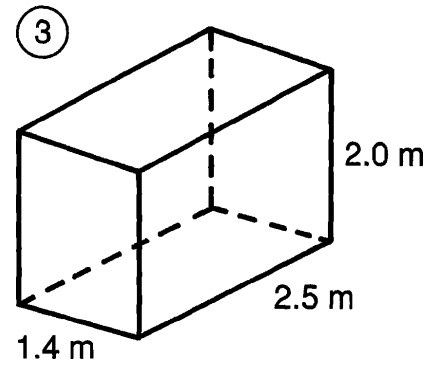
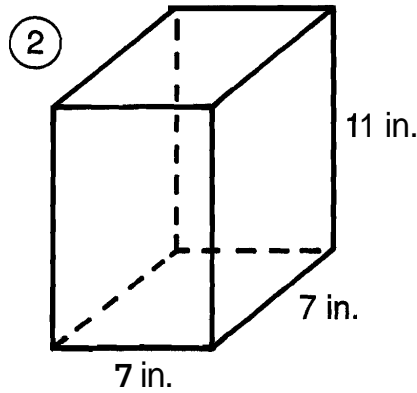
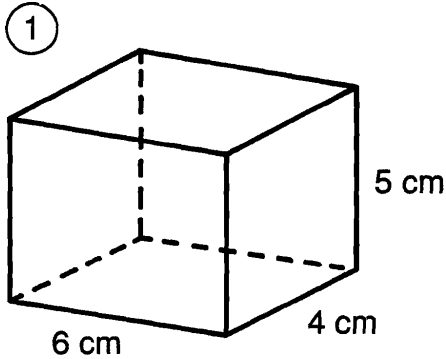

MU	RI	CH	OW	OP	FO	IL
340 m <sup>2</sup>	224 in. <sup>2</sup>	3,120 mm <sup>2</sup>	148 cm <sup>2</sup>	80 in. <sup>2</sup>	3,300 mm <sup>2</sup>	118 in. <sup>2</sup>
IB	AR	CL	EA	CA	NS	KE
81.5 cm <sup>2</sup>	22.6 m <sup>2</sup>	60.45 cm <sup>2</sup>	312 m <sup>2</sup>	145.92 cm <sup>2</sup>	25.8 m <sup>2</sup>	406 in. <sup>2</sup>

--	--	--	--	--	--	--	--	--	--	--	--